



TUFFSTUFF
FITNESS INTERNATIONAL



HOME GYMS SXT-550 & AXT-225R

HYBRID HOME GYM **SXT-550**



Combines popular functional training with traditional press arm and leg station offering the best of both worlds.

- Adjustable seat height and telescopic seat back pad adjustment.
- Combination seated leg extension/ seated leg curl station.
- 6 preset pulleys in three separate training zones.
- Space efficient forward facing exercise design.
- Unique "Radius" frame design that represents TFI quality and craftsmanship.
- 200 lbs. center drilled steel weight stack.

Option:

- SXT-LP Leg Press Attachment

NOTE: SXT-550 is rated for Light Commercial use. See warranty for details on the back page.

CLASSIC HOME GYM **AXT-225R**

Traditional home gym platform providing full body machine based movements and cable outrigger station.

- Adjustable seat height and seat back.
- Leg extension and standing leg curl with low pulley and adjustable foam leg rollers.
- Adjustable press and row bar.
- Mid pulley station.
- Outrigger Arms provide unlimited cable exercises.
- Unique "Radius" frame design that represents TuffStuff quality and craftsmanship.
- 200 lbs. center drilled steel weight stack.

Options:

- SXT-LP Leg Press Attachment.



OPTION **SXT-LP** Leg Press Attachment

- Optional attachment for SXT-550 and AXT-225R.
- Custom convex footplate provides neutral ankle and knee alignment during exercise.
- Adjustable 6-position ergonomic seat carriage with 2" polyurethane rollers riding on 2" diameter hard chrome seat rails for smooth and precise motion.
- 2:1 ratio provides 400 lbs. of weight resistance.



BENEFITS OF REGULAR STRENGTH TRAINING.

Strength training is not just about bodybuilders lifting weights in a gym. It's about conditioning and building muscle that could benefit your heart, improve your balance, strengthen your bones and help you lose weight. It can benefit people of all ages, men and women alike, and particularly people with health issues.

Many people are aware that regular exercise is necessary to stay healthy and many individuals choose cardio/aerobic activity over resistance training. However, recent research has shown that splitting cardio/aerobic and strength training is most beneficial for your health.

According to the American College of Sports Medicine, adults should aim to do muscle-strengthening activities, such as weight lifting at least two times a week. It is extremely important for women to engage in because they are more likely to develop problems with their bones and joints as they age.

- Helps keep the weight off and shapes your physique
- Increased metabolism and improve circulation
- Protects bone health and muscle mass
- Helps develop better body mechanics
- Plays a role in disease prevention
- Boosts energy levels and improves your mood
- Lower stress

Before beginning a new exercise routine, speak to a medical professional to ensure you are healthy enough for any physical activities.

The Surgeon General and the President's Council of Physical Fitness & Sports stated that everyone, young and old, should get thirty minutes of moderate physical activity most days of the week.



OVER 30 MUSCLE SHAPING EXERCISES

SXT-550



Pictured above are some of the over 30 exercises that can be performed on the SXT-550.

OVER 20 MUSCLE SHAPING EXERCISES

AXT-225R



Pictured above are some of the over 20 exercises that can be performed on the AXT-225R.

Features, Specifications & Warranty

FRAME MATERIALS: 11-gauge oval tubular steel frames with a combination of round tubing.

WELDS: All welded construction by inert-gas welding.

FINISH: Electrostatically applied powder coat finish.

FRAME COLORS: Main frame: Platinum Sparkle Accent: Cathedral Gray

UPHOLSTERY: Premium grade naugahyde formulated to resist bacteria, stains, mildew and oil. Meets most flammability test requirements. Standard two-tone (Black/Cadet), double-stitched with "hidden" borders.

PADDING: High density 2" thick rebond urethane foam glued to 1" industrial plywood backing, trimmed and formed to exact fit.

ADJUSTMENT PINS: 1/2" push-pull spring loaded solid steel adjustment pins.

BEARINGS: 1" solid steel pivot axles with non-friction 2" sealed bearings internally encased on primary pivots, and oil-impregnated bronze bushings on all secondary pivots.

GUIDE RODS: 3/4" solid steel hard chrome finish.

CABLES: 3/16" and 1/8" USA-Made/Certified EXERFLEX PRO® high performance fitness cable.

PULLEYS: 4-1/2" and 3-1/2" fiberglass-impregnated nylon pulleys with double sealed roller bearings.

SELECTOR WEIGHT PINS: Solid steel, magnetic with ball-end to ensure a tight connection and secure fit. Coiled lanyard helps prevent pin removal and loss.

FASTENERS: All frame bolts and nuts are 3/8" and 1/2" zinc oxide.

WEIGHT STACK: Solid steel weight plates with self aligning low friction sleeves.

LIGHT COMMERCIAL WARRANTY:

TEN (10) YEARS: Structural main frames, welds, cams and weight plates.

FIVE (5) YEARS: Pivot bearings, pulleys, bushings, guide rods and gas shocks.

ONE (1) YEAR: Cables, linear bearings and pull-pin components.

ALL OTHER PARTS not mentioned elsewhere in the warranty will expire one (1) year from the date of purchase to the original purchaser.

SIX (6) MONTHS: Upholstery, finish and rubber grips.

Light Commercial Use: Light Commercial warranty applies only to facilities like hotels, apartment complexes, personal training studios, fire & police stations, etc. where the equipment would be used by no more than 30 people per day.

HOME LIFETIME WARRANTY*

LIFETIME of the equipment while owned by the original purchaser when used only in a HOME environment (applies to defects from manufacturer only).

* See Owner's Manual for details.

SXT-550

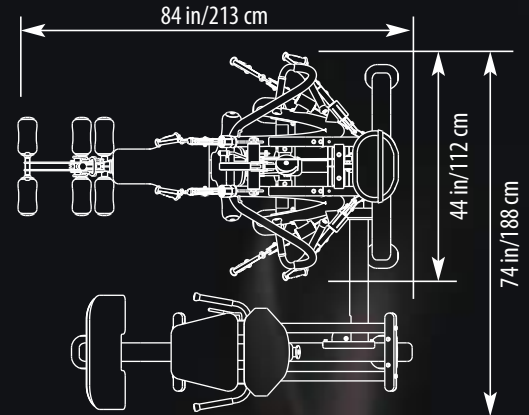

HT: 84 in/213 cm
WT (Base Unit): 670 lb/304 kg
WT (Leg Press): 190 lb/86 kg

AXT-225R

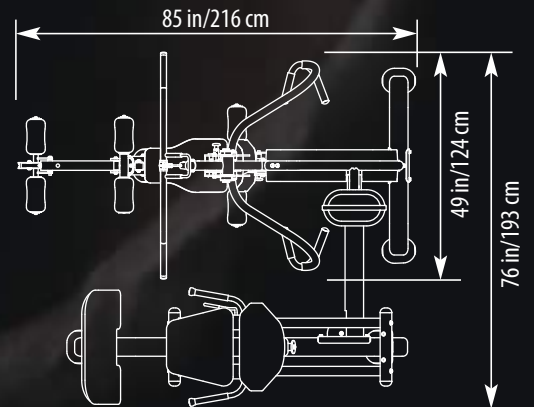

HT: 84 in/213 cm
WT (Base Unit): 550 lb/249 kg
WT (Leg Press): 190 lb/86 kg

NOTICE: TuffStuff continually engages in research related to product improvement. As a result, the product received by the customer may differ slightly from its published description. Improvements in materials, production techniques and design refinements may at any time be introduced into our products. TuffStuff reserves the right to make changes in its product without notice.



13971 Norton Avenue, Chino, CA 91710, USA. PH: 909-629-1600 FX: 909-629-4967
info@tuffstuff.net www.tuffstufffitness.com

12.26.2017_OS0321