

# OWNER'S MANUAL

## Maintenance & Assembly Instructions

**IMPORTANT:** KEEP THIS MANUAL FOR FUTURE REFERENCE



### NOTICE

#### It is the Purchaser's/Owner's obligation:

1. To disclose and post all Rules & Regulations, Danger, Warning and Caution labels affixed on the machine to their customers/users.
2. Equipment to be installed by TuffStuff Authorized Dealer or a service company approved by TuffStuff.
3. Provide trained personnel, supervision and correct usage of the equipment.
4. Provide scheduled inspection, maintenance & repairs and must be performed by TuffStuff Authorized Dealer or a service company approved by TuffStuff.
5. Must use only genuine TuffStuff replacement parts.
6. **▲ WARNING** Machine must be anchored to a solid and level surface.

**TUFFSTUFF**  
FITNESS

## PXLS-7920

**Dual Rack ( 2 Half Racks Back to Back )**

# Table of Contents



DANGER, WARNING, & CAUTION Labels Information.....	Pages 3-6
Anchoring Unit.....	Page 7
Important Safety Instructions.....	Page 8
Registration, Service & Assembly .....	Page 9
Inspection / Maintenance .....	Page 10
Assembly Step 1.....	Page 11
Assembly Step 2.....	Page 12
Assembly Step 3.....	Page 13
Assembly Step 4.....	Page 14
Assembly Step 5.....	Page 15
Assembly Step 6.....	Page 16
Assembly Step 7.....	Page 17
Assembly Step 8.....	Page 18
Notes.....	Page 19
Exploded View Diagram.....	Page 20-21
Parts List.....	Page 22-23
WARRANTY .....	Page 24

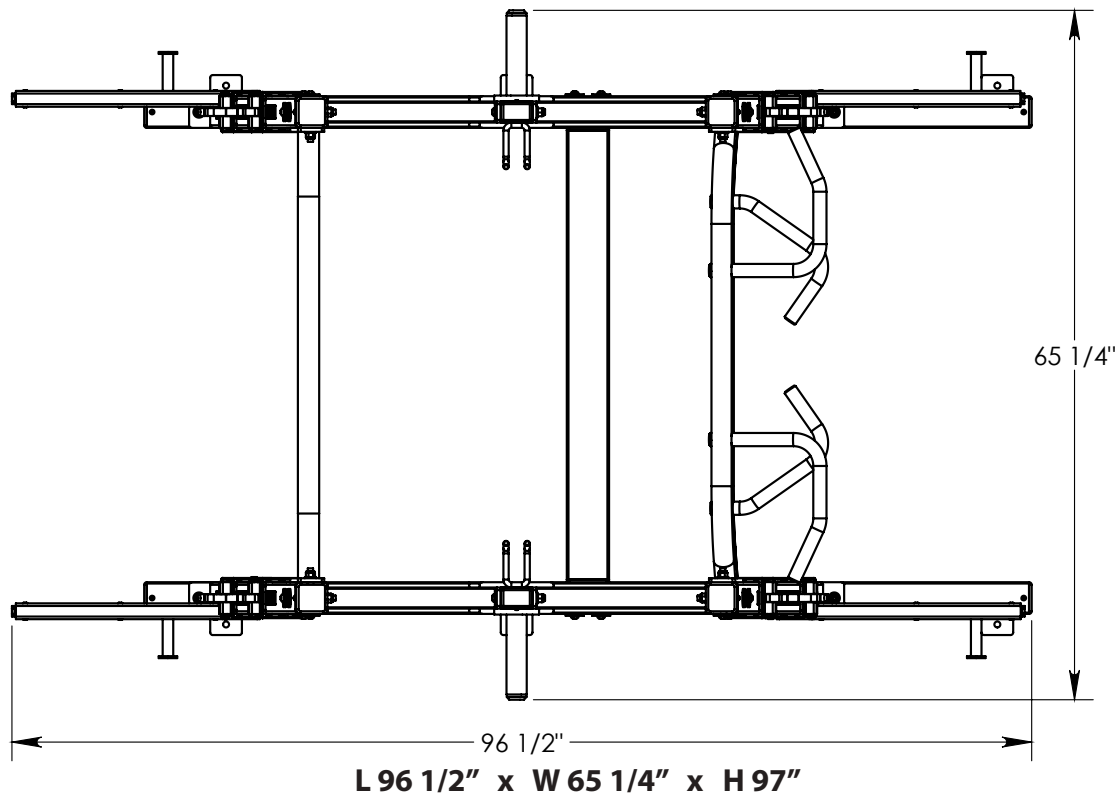

TuffStuff Fitness Equipment Inc. continually engages in research related to product improvements. Please take the time to carefully read through this manual thoroughly. Instructions contained in this manual are not intended to cover all details or variations possible with this equipment, or to cover every contingency that may be met in conjunction with assembly, installation, operation, maintenance or troubleshooting of the equipment. Even though we have prepared this manual with extreme care, neither the manufacturer nor the author can accept responsibility for any errors in, or omission from, the information given. Should additional information be required, or should situations arise that are not covered by this manual, the matter should be directed to Customer Service at TuffStuff Fitness Equipment Inc. in Chino, California.

Carefully read ALL Danger, Warning & Caution labels posted on the machine

64

**! DANGER**

Use this equipment **ONLY** for its intended purpose. If you are unfamiliar with the equipment or procedure, refer to your Owner's Manual or call TuffStuff at 888-884-8275.

Failure to comply could result in serious injury or death.  
BNH2903

63

**! DANGER**

**SAFETY SPOTTER** must be adjusted to the same height on both sides and set to your range of motion for lowering.

Failure to do so could result in serious injury or death.  
BNH3018

62

**! DANGER**

Must use **SPOTTERS/HELPERS** to assist you with this equipment. Failure to do so could result in serious injury or even death.  
BNH2905

73

**! WARNING**

**MAXIMUM WEIGHT LOAD 900 lbs.**

DO NOT exceed the maximum weight capacity. Failure to comply could result in serious injury or death.  
BNH3020

61

**! WARNING**

Serious injury or death can occur if these rules and precautions are not observed:

1. **Read and Understand** Owner's Manual (if available) and all DANGER, WARNING and CAUTION labels before using this equipment. If you still need help, seek assistance from floor personnel.
2. Obtain a **medical exam** before beginning any exercise program.
3. **Stop exercising** if you feel faint or dizzy. Consult a physician if you are experiencing pain.
4. **Inspect equipment** prior to use for wear and tear, loose fittings, worn or frayed cables/belts and frame welds. Do not use if it appears damaged or inoperable.
5. **Do not attempt to fix** or free any jammed parts by yourself. Seek assistance from floor personnel.
6. **Use this equipment only for the intended use** and for exercise(s) shown in the exercise label.
7. Keep body, clothing and hair **clear from all moving parts**.
8. **Children must not be allowed** near this machine. Teenager must be supervised.
9. **Make sure the selector pin** is completely inserted. Use only the selector pin provided by the manufacturer. If difficulty inserting the pin, seek assistance from floor personnel.
10. **Never pin the weights in an elevated position.** Do not use the machine if found in this condition. Inform floor personnel immediately.
11. **Do not modify selectorized weight stack** with any add-on incremental weights or dumbbells, except those with standard factory installed.
12. **Do not remove labels** affixed to the machine. Replace if damaged.

TuffStuff Fitness Equipment Inc.  
Chino, CA 91710, USA  
BNH2939

67

**WARRANTY COMMERCIAL**

**TEN (10) YEARS:**

- Frames, welds, cams and weight plates

**FIVE (5) YEARS:**

- Pivot bearings, pulleys, bushings, gas shocks and guide rods

**ONE (1) YEAR:**

- Belts, linear bearings and pull-pin components

**ALL OTHER PARTS** not mentioned, one year from the date of delivery to the original purchaser.

**SIX (6) MONTHS:**

- Upholstery, cables, finish and rubber grips

**The warranty set forth herein are conditioned upon proper storage, installation, use and maintenance.**

All warranty periods begin to run from the date of delivery to the original purchaser. The obligation of TuffStuff under this warranty is limited to repairing or replacing warranted defective parts, as TuffStuff may elect, at TuffStuff's facility in Chino, California, without charge to the Purchaser for either parts or labor. Purchaser is responsible for installation of repaired or replaced parts, and all transportation and insurance costs to and from TuffStuff's facility in Chino. For a detailed copy of the warranty, please contact:

TuffStuff Fitness Equipment Inc.  
Chino, CA 91710, USA  
www.tuffstufffitness.com  
BNH2927



69

66

**INSPECTIONS**

Recommended Inspection	DAILY	WEEKLY	MONTHLY	6-MONTH
Replace all parts at first signs of wear or damage.				
<b>INSPECT:</b> Links, pull-pins, snap locks, swivels, connectors, selector pin, welded-joints		X		
<b>INSPECT:</b> All decals			X	
<b>CLEAN:</b> Upholstery with lanolin-base cleaner		X		
<b>INSPECT:</b> All nuts and bolts (tighten if needed)			X	
<b>INSPECT:</b> Accessory bars, handles, rubber grips			X	
<b>LUBRICATE:</b> Seat sleeves, pull-pin sliding mechanism, bushings				X
<b>CLEAN &amp; WAX:</b> All powder-coat finishes				X

Use only genuine TuffStuff replacement parts. Failure to do so will void warranty and could result in serious injury or death.

TuffStuff Fitness Equipment Inc.  
13971 Norton Avenue  
Chino, CA 91710, USA  
BNH2915

70

**TUFFSTUFF**  
SER# 000000

65

**IMPORTANT**

For smooth performance, lubricate all gliding surfaces with silicone spray lubricant.  
BNH2916

57

**SCHEDULE Replacement Parts**

Recommended TuffStuff Parts (replace or as needed)	12-MONTH	15-MONTH
Rubber Grips	X	
Rubber U Channel BNH2794		X
Rubber U Channel BNH2795		X
Plastic Tube Guide (w/lip-teeth BNH2874)		X
Labels (as needed)		

Use only genuine TuffStuff parts. Failure to do so will void warranty and could result in personal injury. Warranty period on all parts are one (1) year from date of purchase.

TuffStuff Fitness Equipment Inc.  
Chino, CA 91710, USA  
BNH3013

Carefully read ALL Danger, Warning & Caution labels posted on the machine

56



71

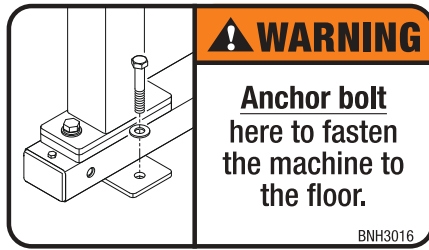

59



60



53



72



54

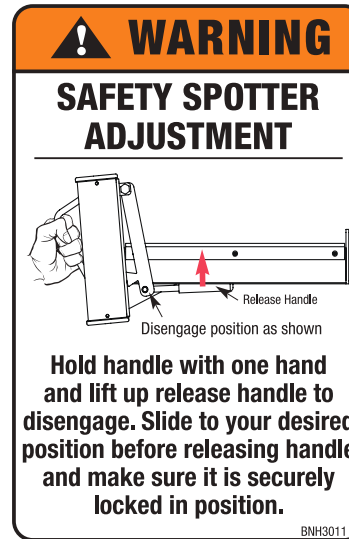

55



68

**BE ALERT!**

**THE FITNESS EQUIPMENT IN THIS FACILITY PRESENTS HAZARDS WHICH, IF NOT AVOIDED, COULD CAUSE SERIOUS INJURY OR DEATH.**

Prior to using the equipment, READ the warning labels and instruction placards affixed to each machine.

If you are unsure on how to use a machine, seek the assistance of our floor personnel. We will be happy to instruct you on how to use the equipment properly.

Immediately report any piece of equipment that is not functioning properly to our floor personnel so that it may be evaluated and service promptly.

**DO NOT ATTEMPT to use or fix any piece of equipment that is not functioning properly.**

ASTM F1749-96 TUFFSTUFF FITNESS EQUIPMENT INC. CHINO, CA 91710 BNH3002

It is extremely important that the **Facility Sign** shown to the left be installed in plain view of the unit.

You should have received it along with this Owners Manual. If you did not receive this Facility Sign with your order, you can obtain one at no cost to you from TuffStuff Fitness by contacting our service department at:

1 (888) 884-8275  
 service@tuffstuff.net  
 service1@tuffstuff.net

Carefully read ALL Danger, Warning & Caution labels posted on the machine

Front View

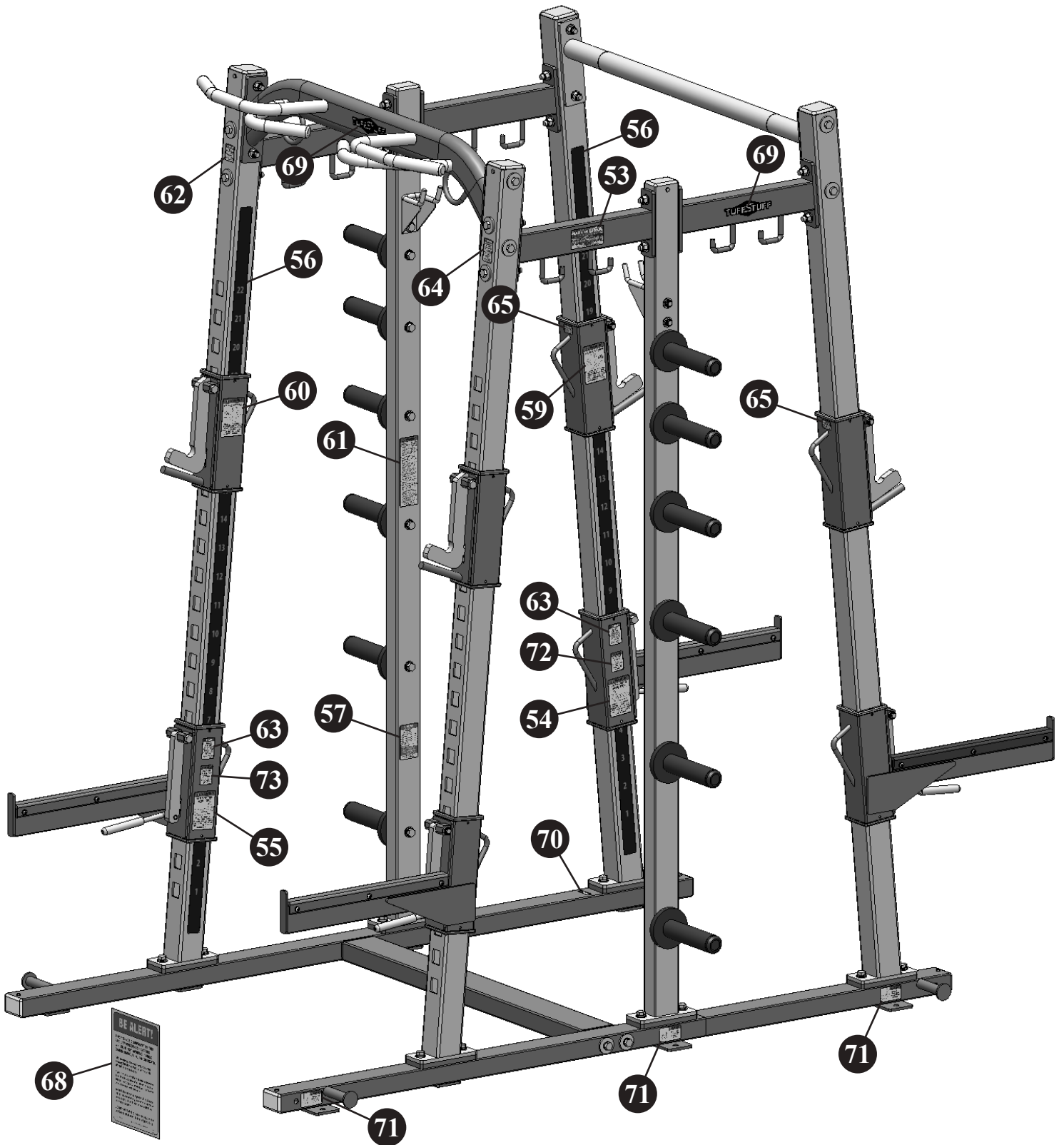

Carefully read ALL Danger, Warning & Caution labels posted on the machine

Rear View

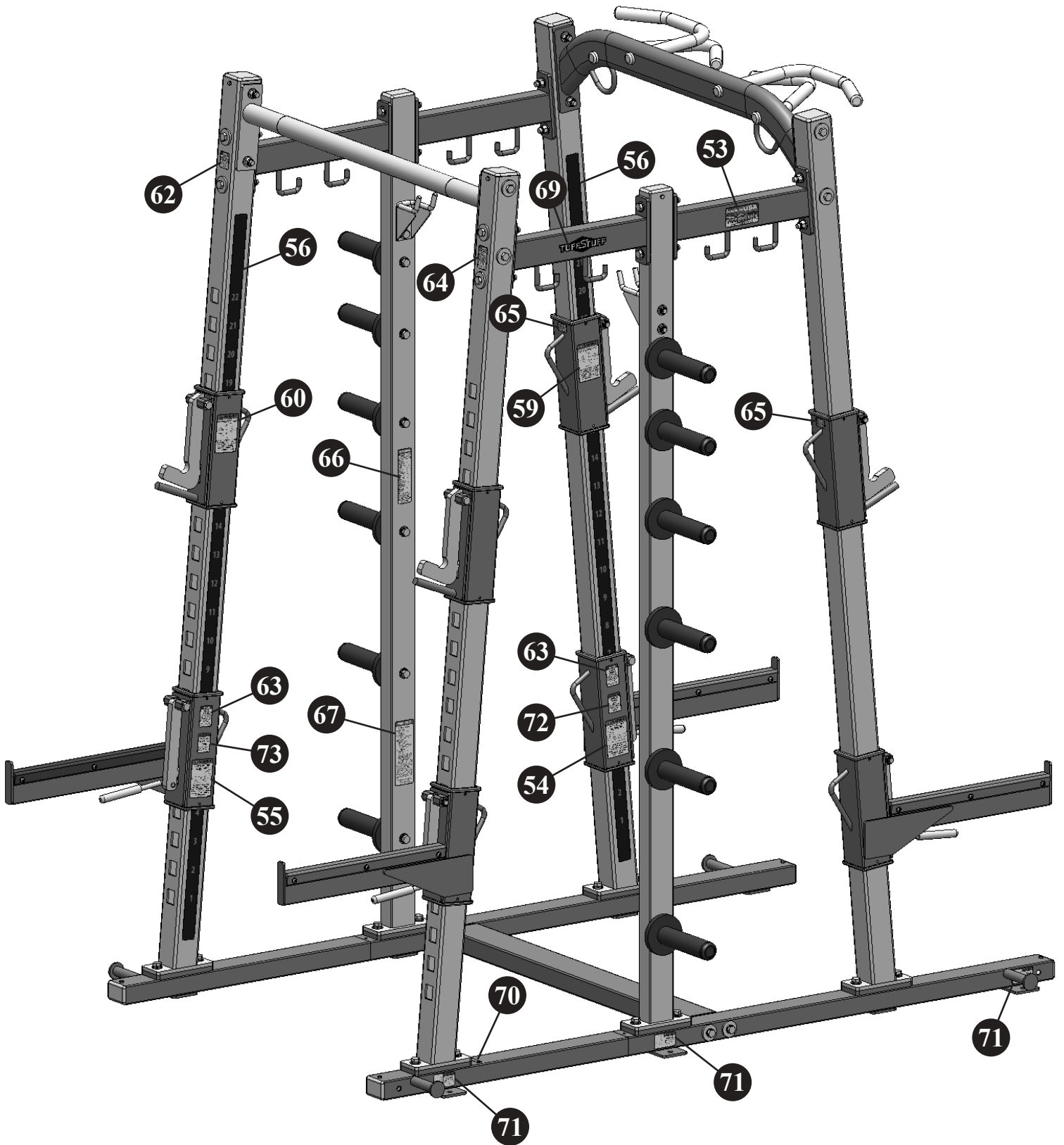

# Anchoring Unit



**⚠ WARNING** Anchoring of equipment must be completed at time of installation and inspected prior to use. Failure to anchor the machine to the floor could cause the machine to tip or fall over due to incorrect usage and misuse, and could result in serious injury or death.

Holes on footplates are provided for anchoring the unit to the floor. (See anchoring hole locations below)



9/16" Diameter Anchoring Hole

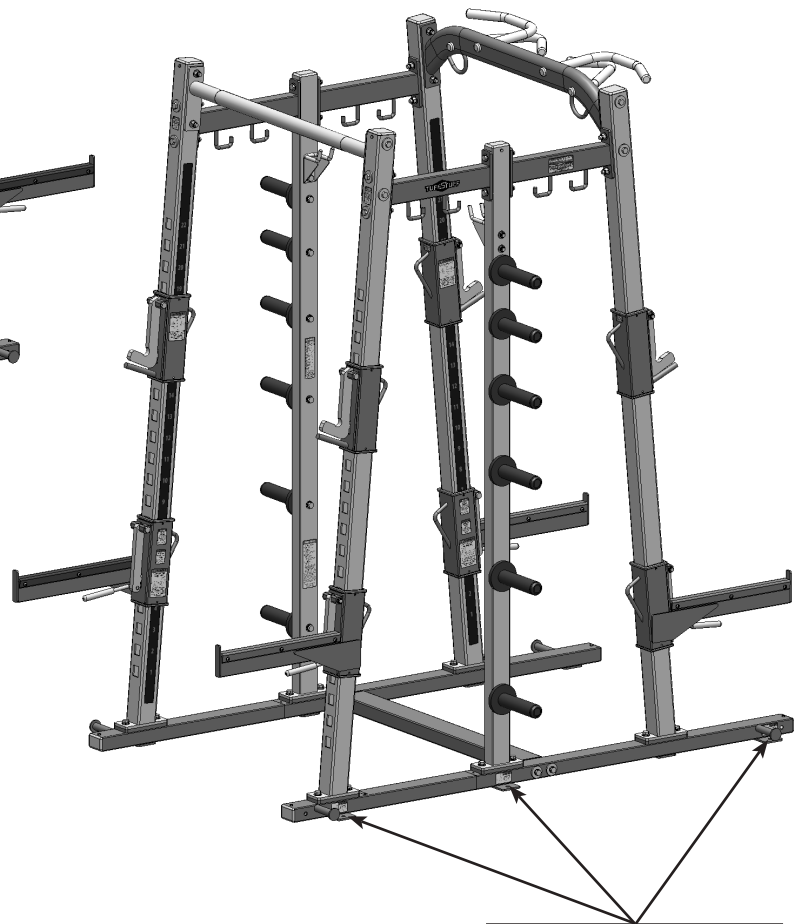

9/16" Diameter Anchoring Hole

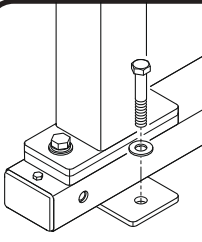

**⚠ WARNING**  
Anchor bolt here to fasten the machine to the floor.  
BNH3016

# Important Safety Instructions



*It is the responsibility of the facility owner and/or owner of the equipment to review the Owner's Manual with their facility personnel and understand all Danger, Warning and Caution labels affixed on the machine. It is the responsibility of the floor personnel to instruct users on proper operation of the equipment and review all danger, warning and caution labels.*

## **WARNING** SERIOUS INJURY OR DEATH CAN OCCUR IF THESE SAFETY PRECAUTIONS ARE NOT OBSERVED:

1. Obtain a medical exam before beginning any exercise program.
2. Read and understand Owner's Manual and all **Danger, Warning and Caution** labels before using this equipment. If you still need help, seek assistance from floor personnel.
3. **Inspect the equipment** before each use for wear and tear, loose fittings, worn or frayed cables and frame welds. DO NOT USE if it appears to be inoperable or damaged.
4. Stop exercising if you feel faint or dizzy. Consult a physician if you are experiencing pain.
5. Keep body, clothing and hair clear from all moving parts. Do not attempt to free any jammed parts by yourself.
6. Always warm-up before and cool-down after weight training. Warm-up for 10-15 minutes with stretching and cardiovascular exercises. Cool-down should include light stretching exercises for 5-15 minutes.
7. Never hold your breath – will limit the flow of oxygen to your brain and may cause dizziness. The most often used breathing pattern is inhaling during least resistance and exhaling during maximum resistance.
8. Do not use accessories or accessory attachments that are not recommended by TuffStuff.
9. Do not use the Safety Spotters for racking the bar. Always use the Bar Catches.
10. Make sure adjustment pull-pins and Swing Lock J-Hooks are completely inserted and fully engaged before each use.
5. Provide an adequate safety perimeter between the machine, walls and other equipment to ensure that the facility has proper clearance for usage and training.
6. Post and disclose all safety, rules and regulations on a bulletin board easily accessible to users.
7. Perform regular maintenance (see Inspection Label). Pay special attention to areas most susceptible to wear and tear.
8. **Do not** lean against or pull on the framework, weight stack or any component at all times.
9. **Children must not** be allowed near the equipment. Teenager must be supervised.
10. Replace immediately all parts at first sign of wear or damage. If unable to replace worn or damaged components/parts, remove machine from service until the repair is made.
11. Use only genuine TuffStuff replacement parts. Failure to do so will void warranty and could result in serious injury or death to the users.
12. **Do not remove** any LABELS affixed to the machine. Replace if damaged.
13. Maintain a service contract with a TuffStuff Authorized Dealer or a Professional Service Company approved by TuffStuff. Keep a service log of all maintenance and repair activities. **NOTICE:** It is the sole responsibility of the owner or facility operator to ensure that regular maintenance is performed.

## Facility Safety Guidelines and Practices

1. Read and understand the Owner's Manual before assembling, servicing or using the equipment.
2. Equipment to be installed by TuffStuff Authorized Dealer or Professional Service Company approved by TuffStuff.
3. Make sure each machine is set up and operated on a solid level surface. Do not install equipment on an uneven surface.
4. **Anchoring of equipment must be completed** at time of installation and inspected prior to use. Failure to anchor the machine to the floor could cause the machine to tip or fall over due to incorrect usage and misuse, and could result in serious injury or death.

 **WARNING** MAXIMUM WEIGHT LOAD 900 LBS. DO NOT exceed the maximum weight capacity. Failure to comply could result in serious injury or death.



**DANGER:** indicates an imminently hazardous situation which, if not avoided, will result in death or serious injury.



**WARNING:** indicates a potentially hazardous situation which, if not avoided, will result in death or serious injury.



**CAUTION:** indicates a hazardous situation which, if not avoided, could result in minor or moderate injury.

Thank you for purchasing the **PXLS-7920 Dual Rack ( 2 Half Racks Back to Back )**. This machine is part of the TuffStuff line of quality strength training equipment. To maximize your use of the equipment, please study the **Owner's Manual** thoroughly.

## Registration

To avoid unnecessary delays on warranty parts and to insure that a permanent record of your purchase is on file with our company, be sure to register online at [www.tuffstufffitness.com](http://www.tuffstufffitness.com) within 10 days of purchase.

## Obtaining Service

Please use this Owner's Manual as your guide to all parts included in your shipment. When ordering parts, you must specify the part number and description from this manual. **Use only genuine TuffStuff replacement parts when servicing the equipment.** Failure to do so will void warranty and could result in serious injury or death.

For information about product operation or service:

Phone: 909-629-1600 Toll Free 888-884-8275  
Fax: 909-629-4967  
E-mail: [service@tuffstuff.net](mailto:service@tuffstuff.net) or [service1@tuffstuff.net](mailto:service1@tuffstuff.net)  
Hours: M-F 8:00 – 4:30 PST  
Or write to: TuffStuff Fitness Equipment Inc.  
Customer Service  
13971 Norton Avenue, Chino, CA 91710

**Retain this Owner's Manual for future reference when ordering service or parts. To assist you better, please be prepared to provide the following information:**

1. Model Number
2. Place of Purchase
3. Serial Number
4. Part # and Description

## Required Tools

The basic tools that you will need to assemble the PXLS-7920 but are not limited to:

- 7/16", 3/4" Combination Wrenches
- Ratchet Wrench with 7/16", 3/4" sockets
- Two Strong Step Ladders
- Rubber mallet, measuring tape & utility knife
- Windex or household glass cleaner

## Assembly Requirements

Follow these installation requirements when assembling the PXLS-7920. Use the overhead view on the Content Page to layout your floor plan before assembling.

Set up the PXLS-7920 on a clean, solid, flat surface. A smooth, flat surface under the machine helps keep it level.

Allow ample space around the machine for safe unrestricted use and easier access.

Insert all bolts in the same direction. For aesthetic appearance, insert all bolts in the same direction unless specified (in text or illustration) to do otherwise.

Leave room for adjustments. Do not fully tighten fasteners until instructed in the assembly steps to do so (to prevent any difficulty with alignment of parts during the assembly process). When not instructed, tighten fasteners such as bolts, nuts and screws so the unit is stable, but leave room for adjustments.

## Assembly Tips

Read all "Notes" on each page before beginning each step.

While you may be able to assemble the PXLS-7920 using the illustrations only, **IMPORTANT** safety notes and other tips are included in the text.

Some pieces may have extra holes that you will not use. Use only those holes indicated in the instructions and illustration.

**NOTE:** With so many assembled parts, proper alignment and adjustment is critical. While tightening the nuts and bolts, be sure to leave room for final adjustments.

**CAUTION:** Obtain assistance from TuffStuff if you have difficulty assembling the PXLS-7920. Please do not attempt to complete the assembly as this could result in equipment failure and serious injuries to the users.

## Symbols & Description

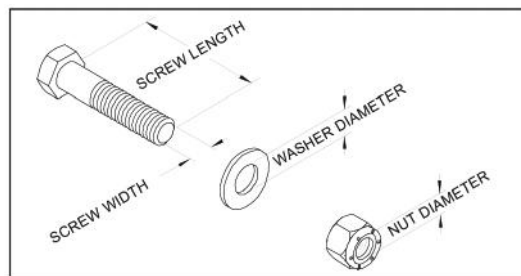

### Loosely Fasten

Finger tighten all hardware in this step. **DO NOT** wrench tighten. Some component(s) may need pre-assembly and alignment during the assembly process.



### Fully Fasten

Wrench tighten all hardware in this step.



# Assembly Step 1



Step 1 Assembly List		
Item #	Description	Qty.
2	BOTTOM CONNECTOR 43"	1
3	BOTTOM SIDE FRAME 44 3/4" LT	1
4	BOTTOM SIDE FRAME 44 3/4" RT	1
5	BOTTOM SIDE FRAME 53" LT	1
6	BOTTOM SIDE FRAME 53" RT	1
25	ALUMINUM INSERT CAP 2 X 3	4
33	HEX HEAD CAP SCREW GR-5 Z/P 1/2-13 X 4 1/2	4
35	HEX HEAD CAP SCREW GR-5 Z/P 1/4-20 X 3/8	4
37	FLAT WASHER Z/P 1/2 X 1 3/4 X 3/16	4
47	SPLIT LOCK WASHER Z/P 1/2"	4

## Step 1 Assembled View

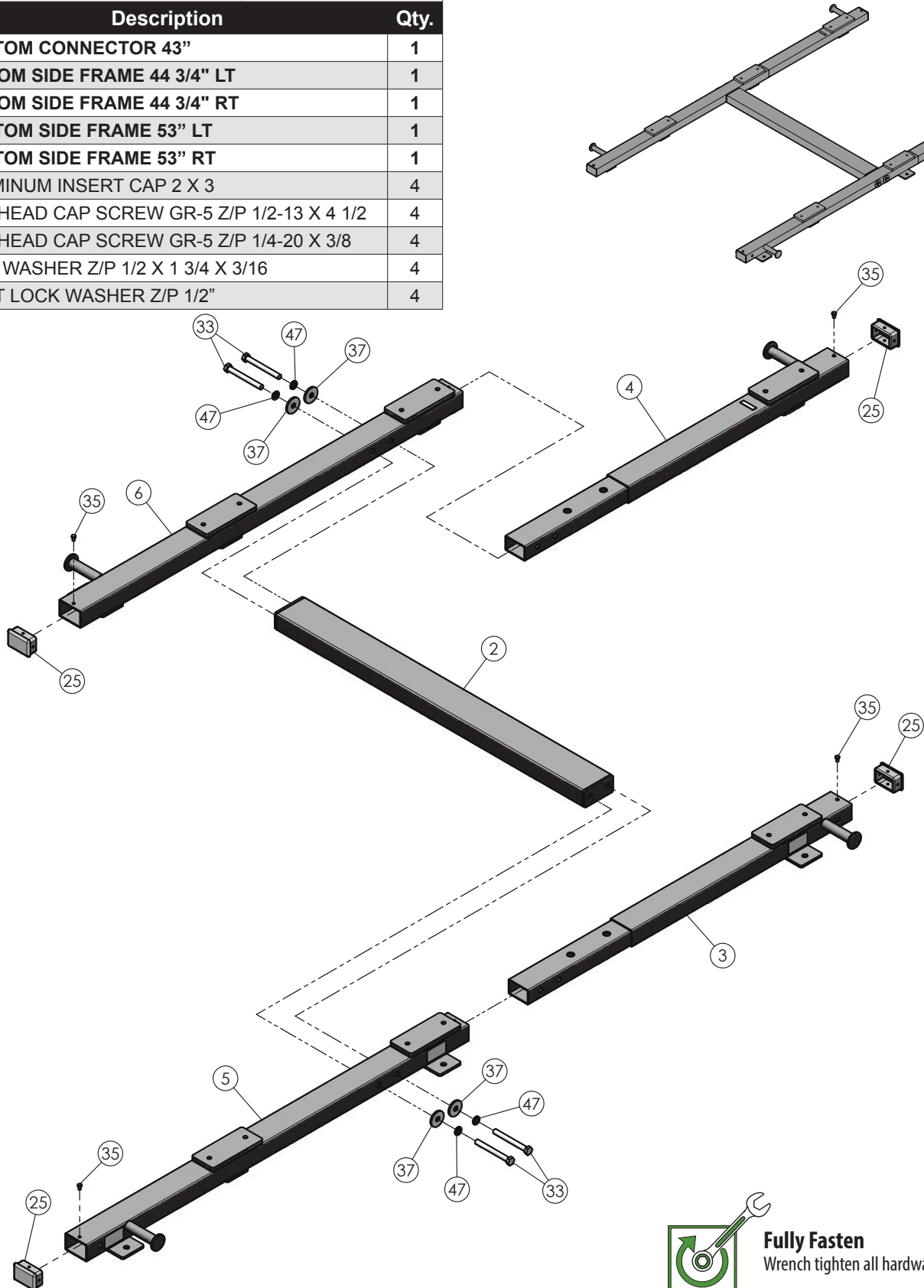

**Fully Fasten**  
Wrench tighten all hardware in this step.

**⚠ WARNING** IT IS RECOMMENDED TO HAVE ANOTHER PERSON ASSIST YOU WITH THE INSTALLATION OF THIS UNIT.

# Assembly Step 2

## Step 2 Assembly List

Item #	Description	Qty.
10	OLYMPIC ADAPTER 1 X 8 (1 3/4 AXLE)	10
24	UPRIGHT, WEIGHT HOLDER	2
30	HEX HEAD CAP SCREW GR-5 Z/P 1/2-13 X 1 1/4	14
38	FLAT WASHER SAE Z/P 1/2"	14
45	RUBBER WASHER 1 7/8 ID X 4 1/4 OD X 9/16 TK	10
47	SPLIT LOCK WASHER Z/P 1/2"	14

## Step 2 Assembled View

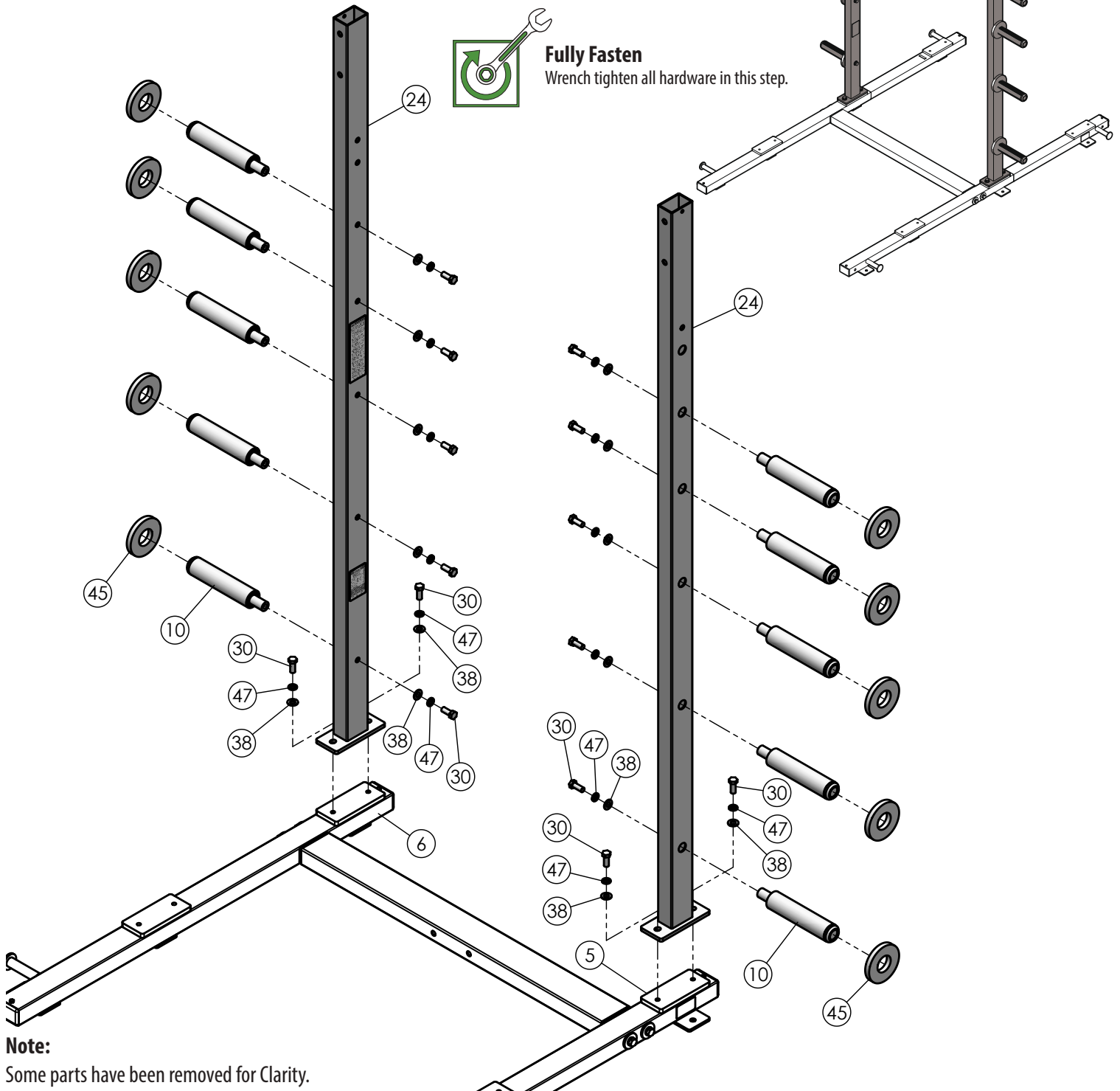

**Note:**  
Some parts have been removed for clarity.

# Assembly Step 3

## Step 3 Assembly List

Item #	Description	Qty.
10	OLYMPIC ADAPTER 1 X 8 (1 3/4 AXLE)	2
25	ALUMINUM INSERT CAP 2 X 3	2
30	HEX HEAD CAP SCREW GR-5 Z/P 1/2-13 X 1 1/4	2
35	HEX HEAD CAP SCREW GR-5 Z/P 1/4-20 X 3/8	2
38	FLAT WASHER SAE Z/P 1/2"	6
39	NYLON INSERT THIN LOCK NUT Z/P 1/2-13	2
45	RUBBER WASHER 1 7/8 ID X 4 1/4 OD X 9/16 TK	2
47	SPLIT LOCK WASHER Z/P 1/2"	2
74	OLYMPIC BAR STORAGE HOOK (Pxls)	2
75	HEX HEAD CAP SCREW GR-5 Z/P 1/2-13 X 2 3/4	2

## Step 3 Assembled View

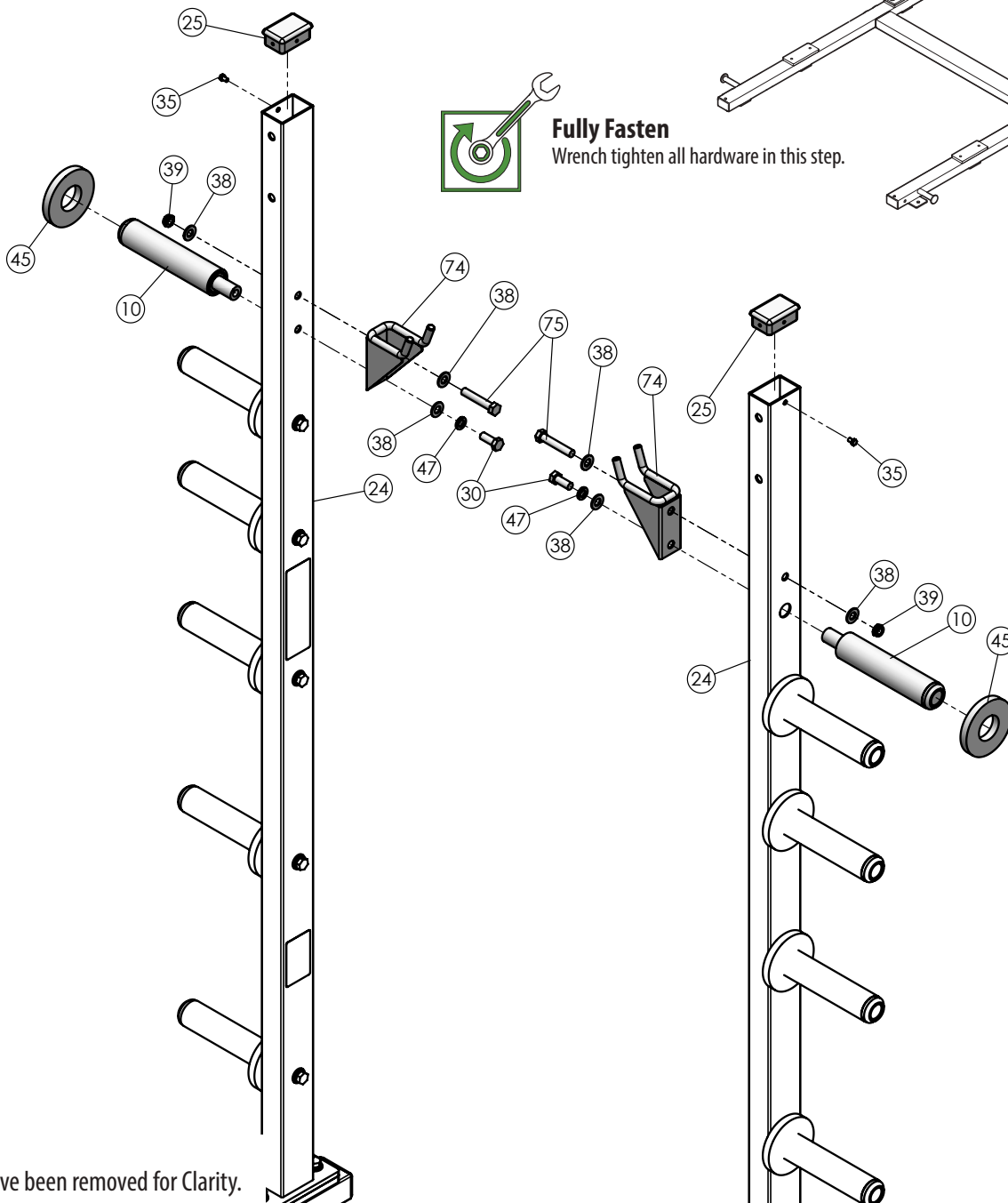
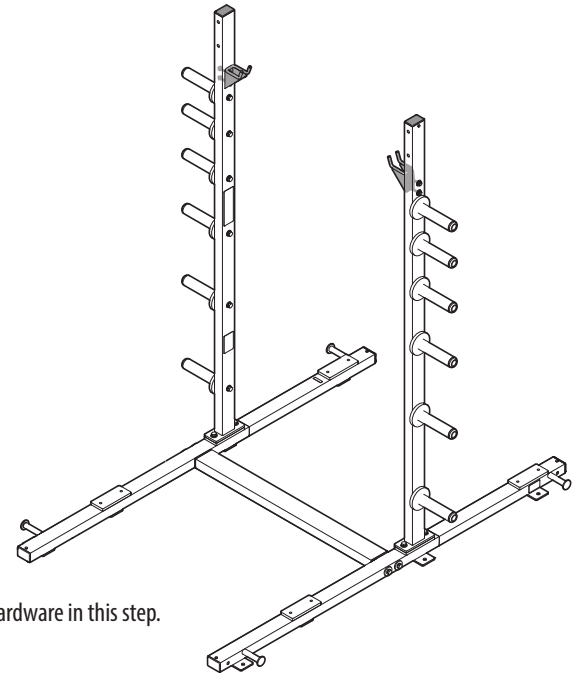

**Fully Fasten**  
Wrench tighten all hardware in this step.

**Note:**  
Some parts have been removed for Clarity.

# Assembly Step 4



## Step 4 Assembled View

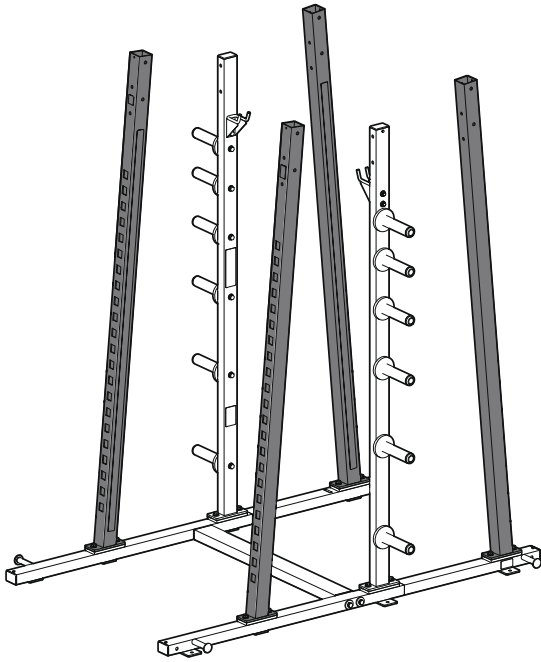

## Step 4 Assembly List

Item #	Description	Qty.
23	UPRIGHT, SLANTED 5 DEG	4
30	HEX HEAD CAP SCREW GR-5 Z/P 1/2-13 X 1 1/4	8
38	FLAT WASHER SAE Z/P 1/2"	8
47	SPLIT LOCK WASHER Z/P 1/2"	8

**Note:**  
Label Numbers facing  
towards the inside of the  
Unit.



### Loosely Fasten

Finger tighten all hardware in this step.  
DO NOT wrench tighten. Some component(s)  
may need pre-assembly and alignment during  
the assembly process.

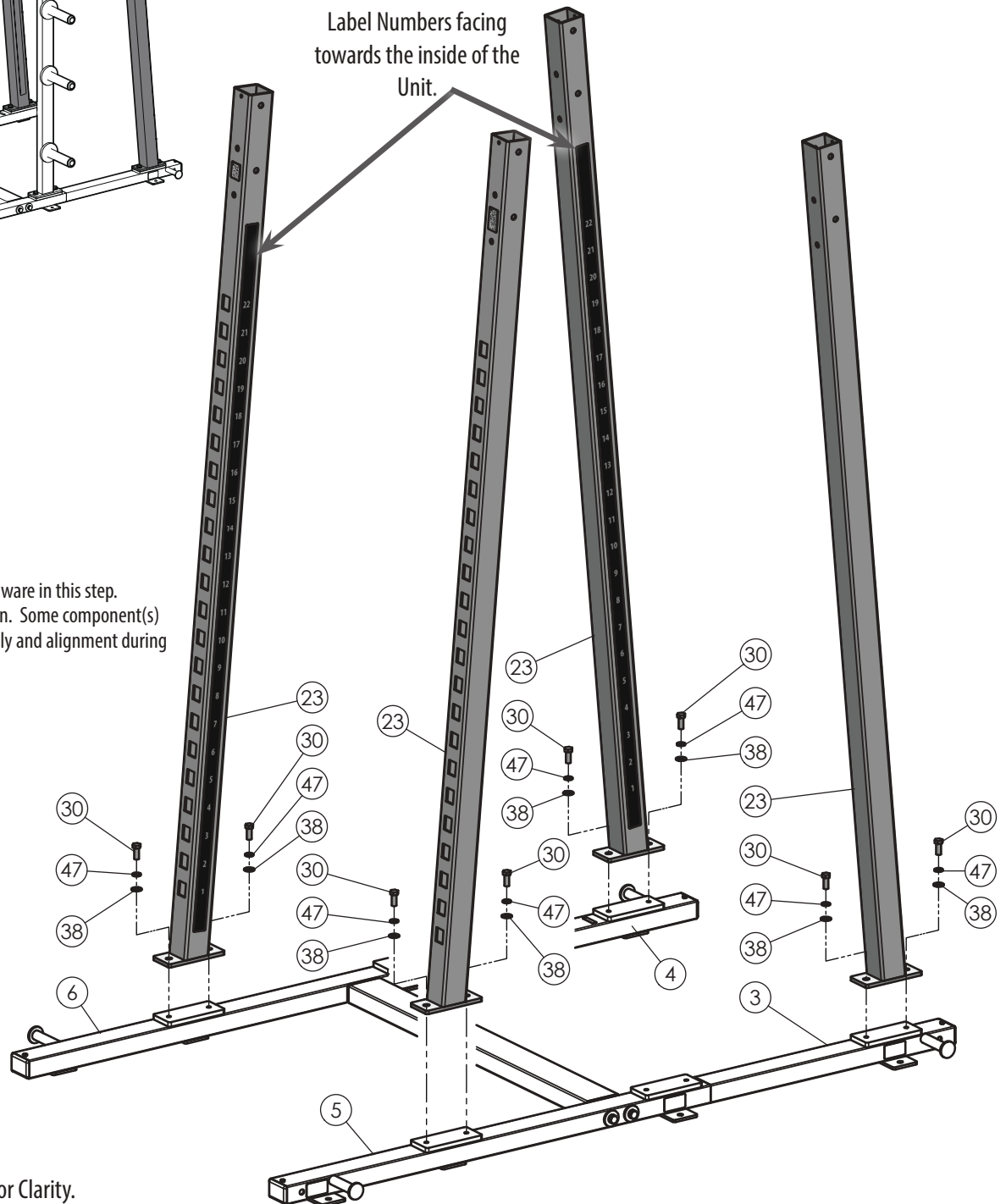

**Note:**  
Some parts have been removed for clarity.

# Assembly Step 5

## Step 5 Assembled View

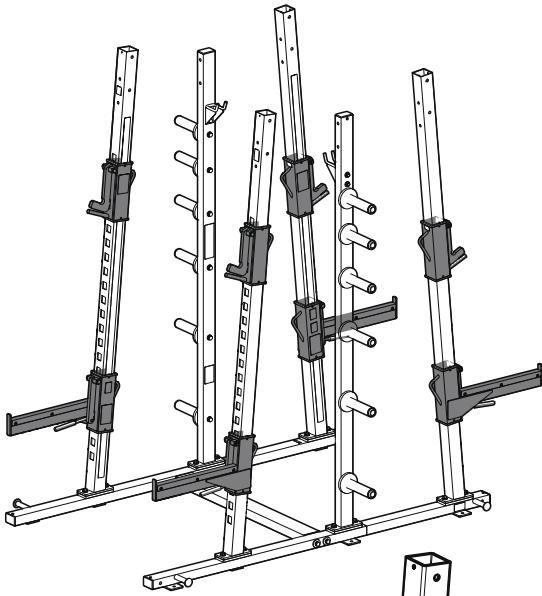

Step 5 Assembly List		
Item #	Description	Qty.
1	BAR-CATCH, SINGLE HOOK	4
14	SAFETY BAR SPOTTER LT	2
15	SAFETY BAR SPOTTER RT	2

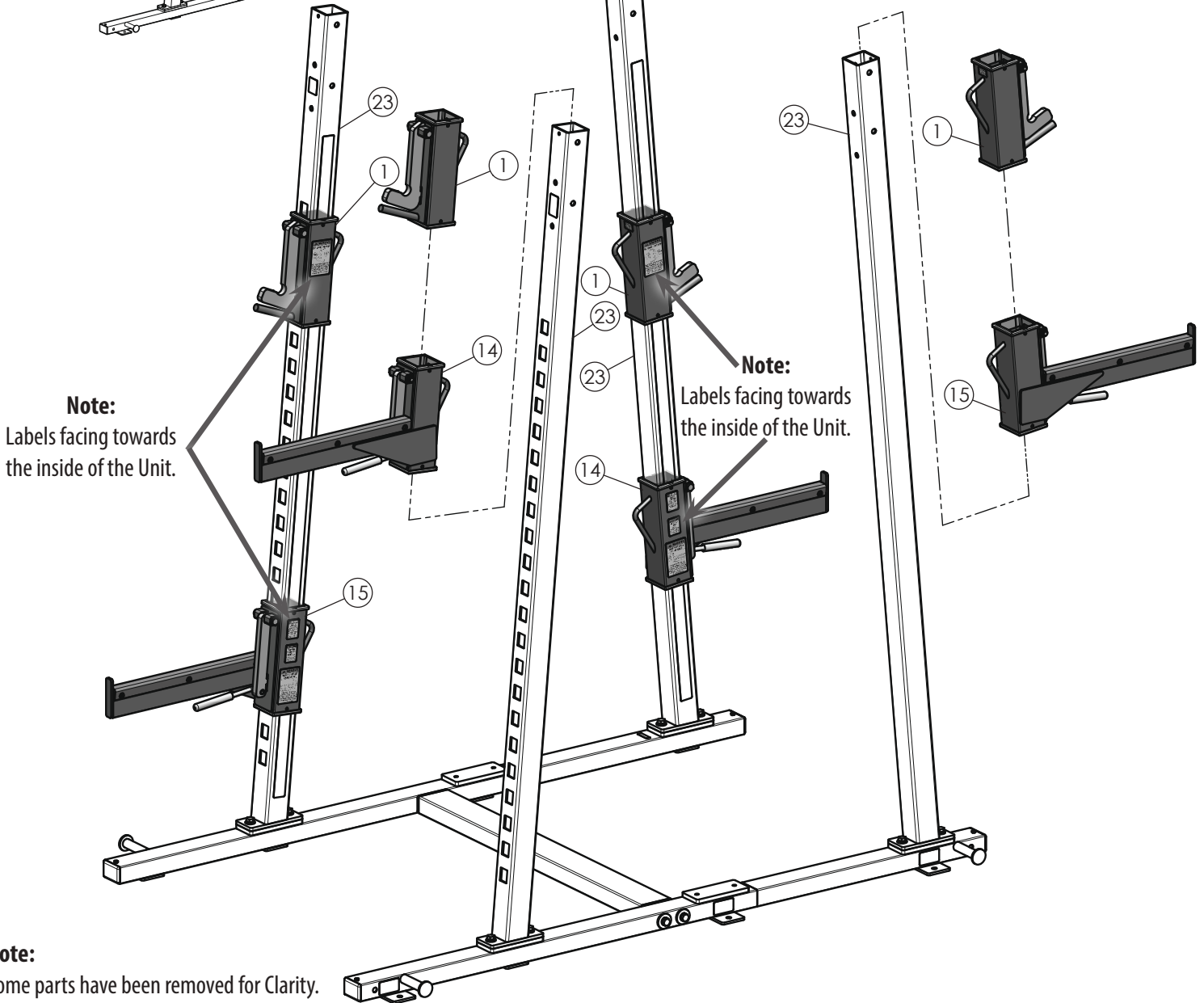

**Note:**  
Some parts have been removed for Clarity.

# Assembly Step 6



## Step 6 Assembled View

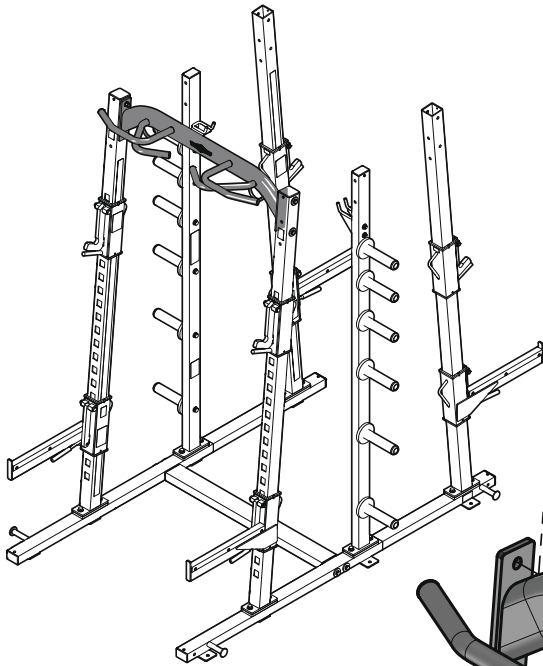

## Step 6 Assembly List

Item #	Description	Qty.
20	TOP CROSS BRACE 43" W/HANDLES	1
26	ALUMINUM INSERT CAP 3 SQ X .188	2
33	HEX HEAD CAP SCREW GR-5 Z/P 1/2-13 X 4 1/2	4
35	HEX HEAD CAP SCREW GR-5 Z/P 1/4-20 X 3/8	2
37	FLAT WASHER Z/P 1/2 X 1 3/4 X 3/16	4
38	FLAT WASHER SAE Z/P 1/2"	4
42	NYLON INSERT LOCK NUT Z/P 1/2-13	4



**Fully Fasten**  
Wrench tighten all hardware in this step.

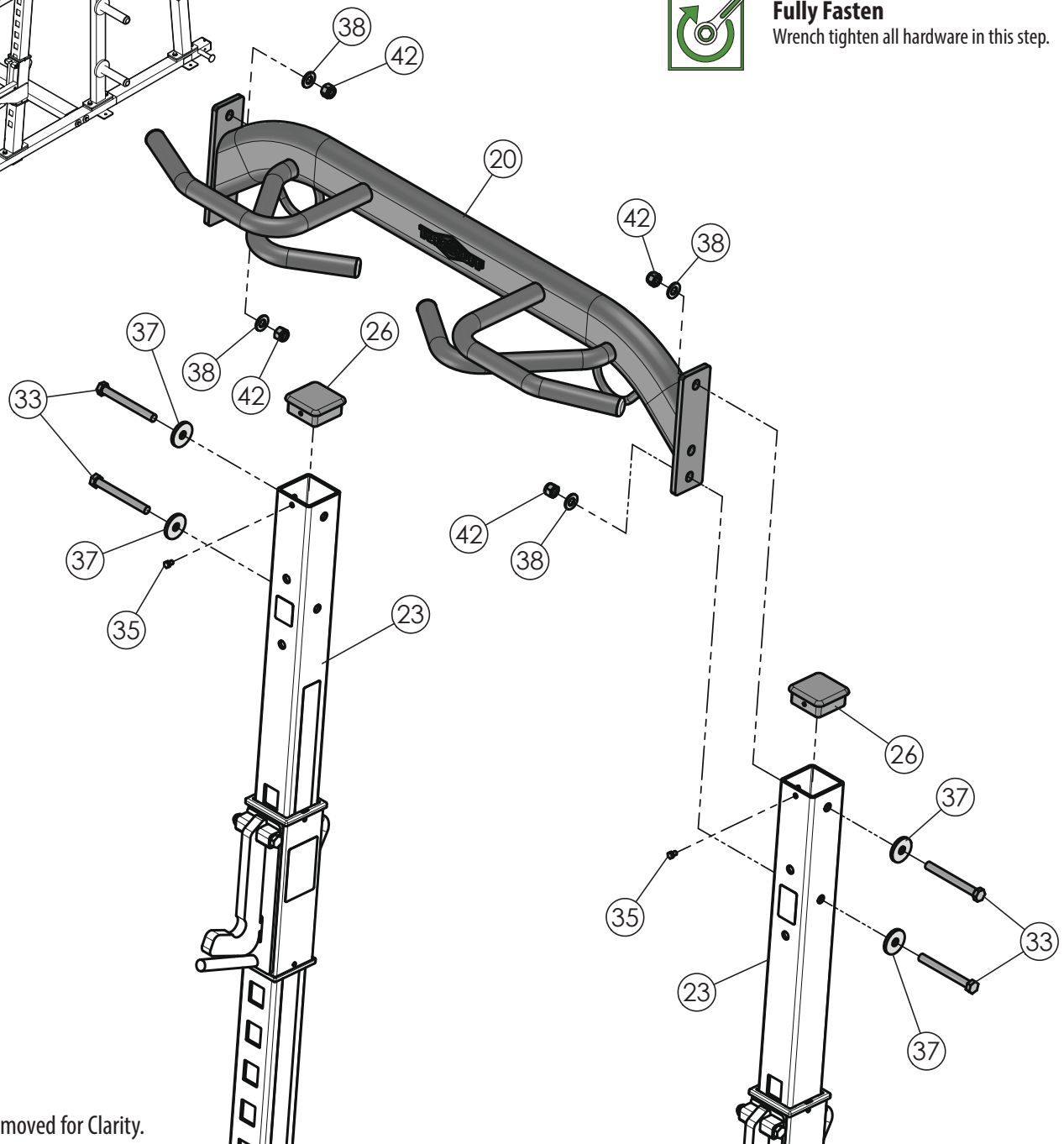

**Note:**  
Some parts have been removed for clarity.

# Assembly Step 7

## Step 7 Assembled View

## Step 7 Assembly List

Item #	Description	Qty.
18	TOP CHIN-UP BRACE 43" W/KNURLING	1
26	ALUMINUM INSERT CAP 3 SQ X .188	2
33	HEX HEAD CAP SCREW GR-5 Z/P 1/2-13 X 4 1/2	4
35	HEX HEAD CAP SCREW GR-5 Z/P 1/4-20 X 3/8	2
37	FLAT WASHER Z/P 1/2 X 1 3/4 X 3/16	4
38	FLAT WASHER SAE Z/P 1/2"	4
42	NYLON INSERT LOCK NUT Z/P 1/2-13	4

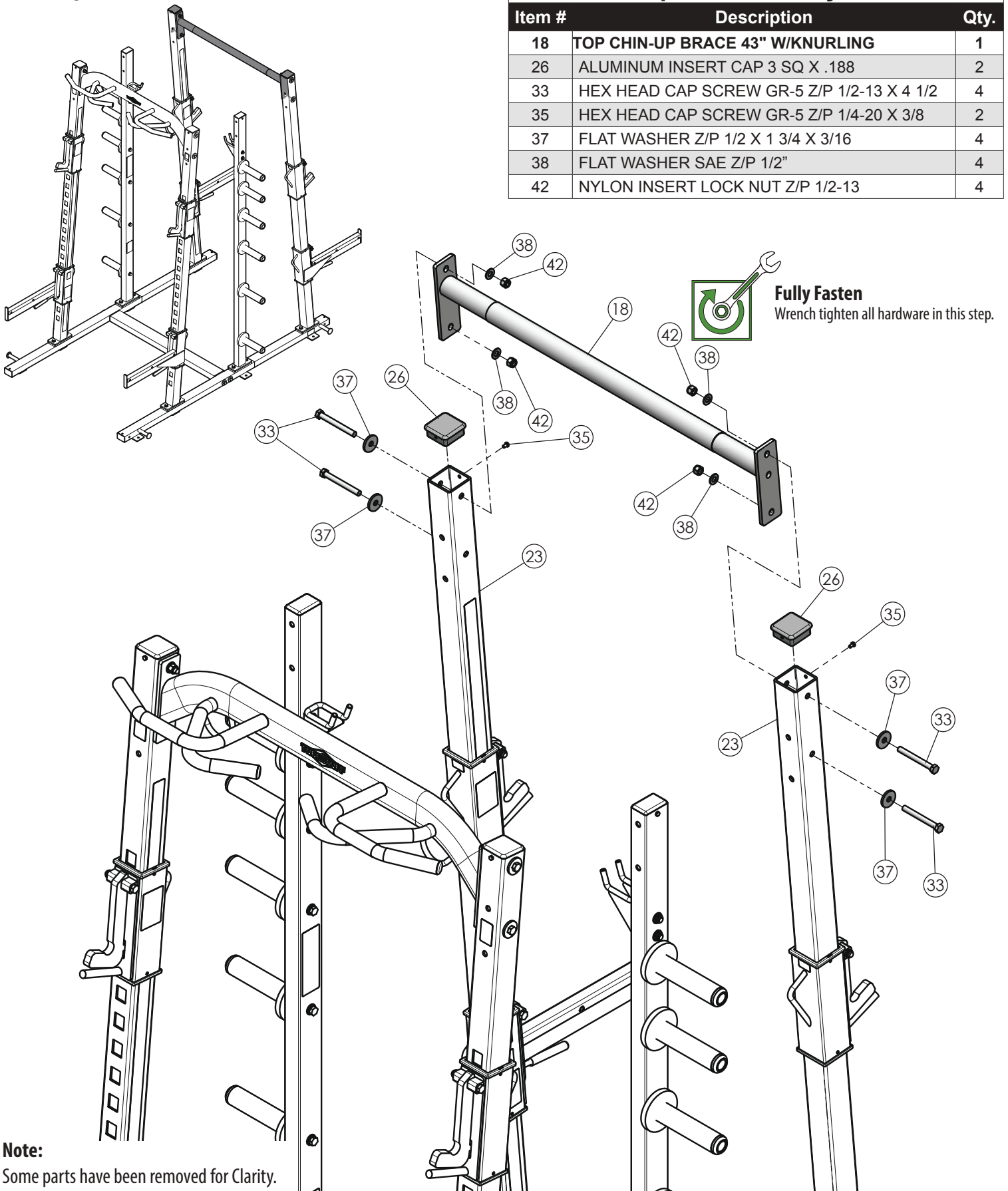

**Note:**  
Some parts have been removed for clarity.

# Assembly Step 8



Step 8 Assembly List		
Item #	Description	Qty.
9	CROSS BRACE, SLANTED PLATE	4
33	HEX HEAD CAP SCREW GR-5 Z/P 1/2-13 X 4 1/2	8
34	HEX HEAD CAP SCREW GR-5 Z/P 1/2-13 X 4 3/4	4
37	FLAT WASHER Z/P 1/2 X 1 3/4 X 3/16	8
38	FLAT WASHER SAE Z/P 1/2"	16
42	NYLON INSERT LOCK NUT Z/P 1/2-13	12

## Step 8 Assembled View

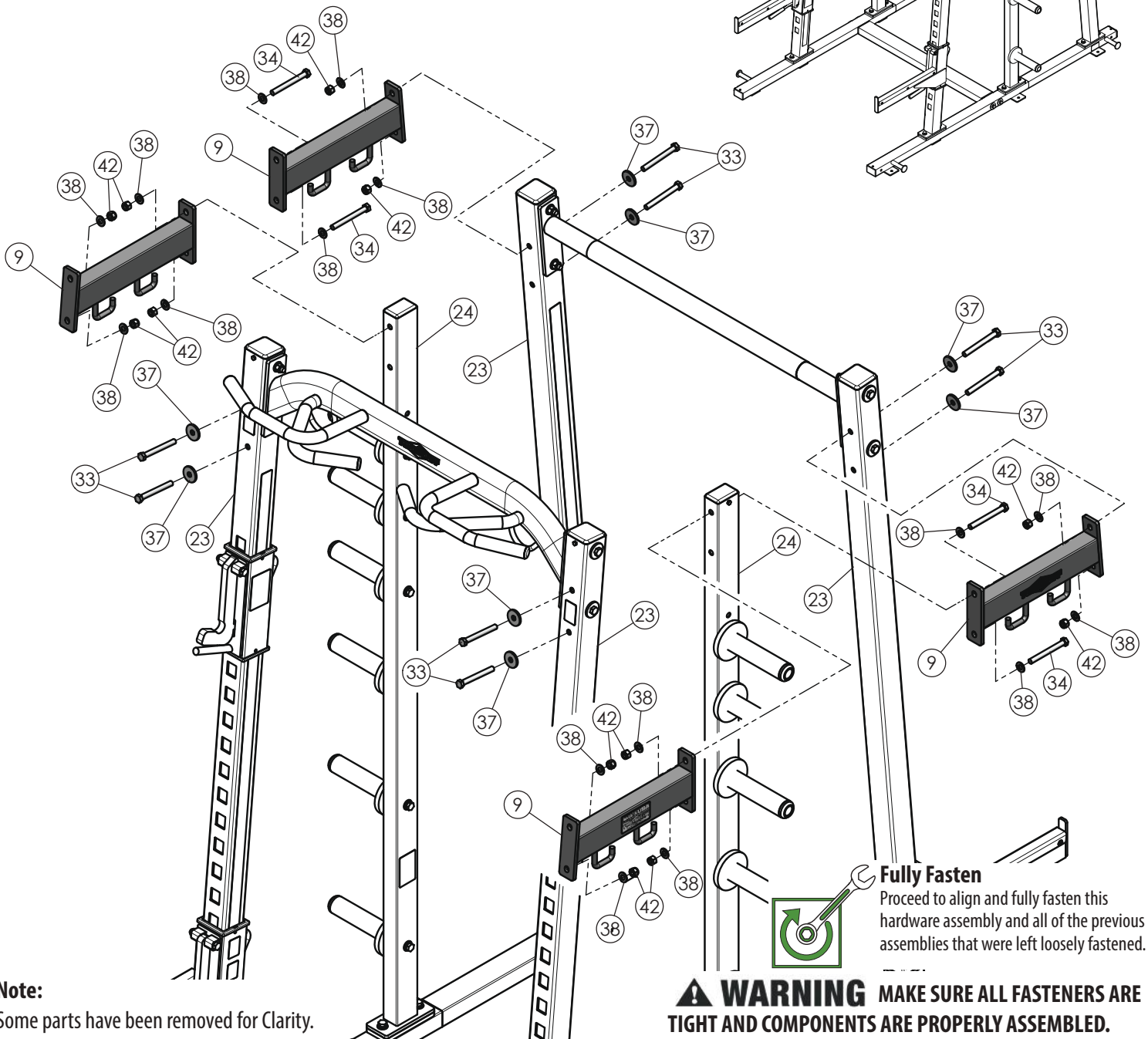
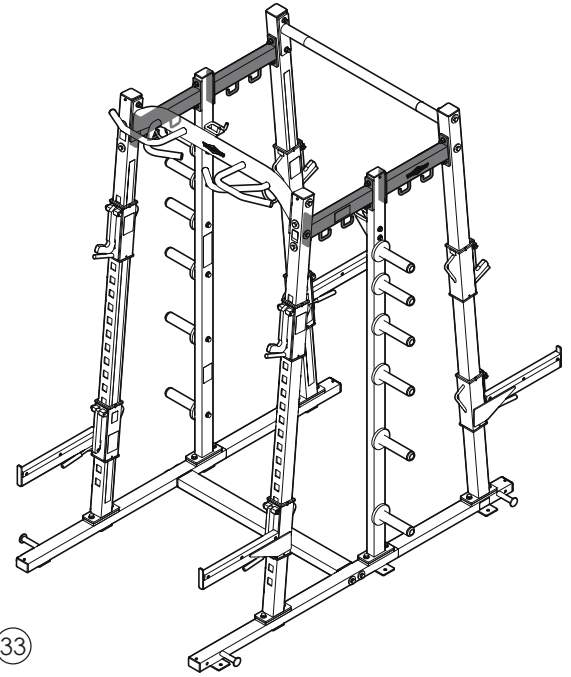

**Note:**  
Some parts have been removed for Clarity.



# Exploded View Diagram

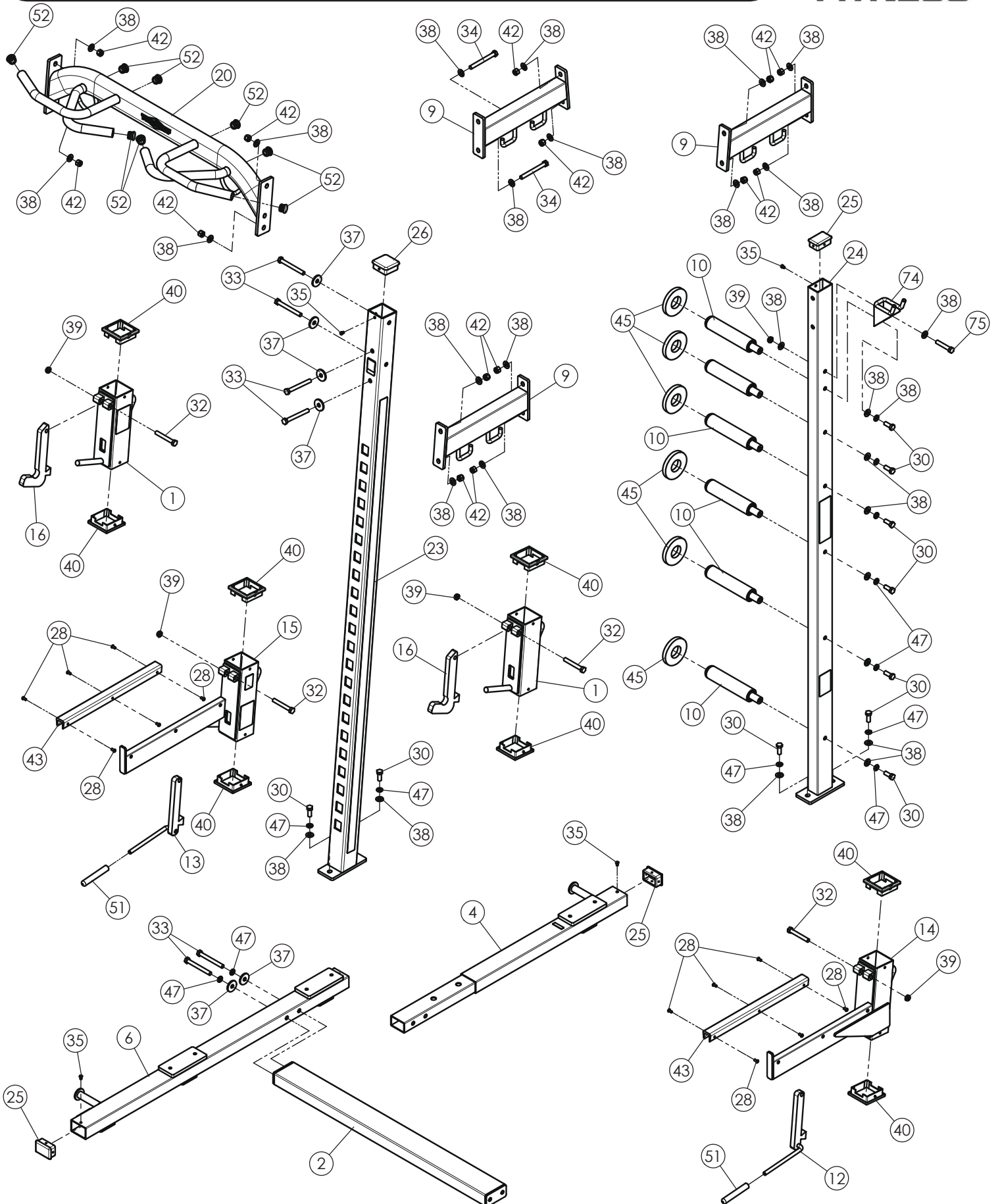



# PXLS-7920 Parts List



ITEM	DESCRIPTION	REV	PART NO.	QTY
1	BAR-CATCH, SINGLE HOOK (PXLS-7950, 7930, 7910, 7900)	0	UP7601	4
2	BOTTOM CONNECTOR 43" (PXLS-7950, 7930, 7910)	0	UP7602	1
3	BOTTOM SIDE FRAME 44 3/4" LT (PXLS-7950, 7900)	0	UP7603	1
4	BOTTOM SIDE FRAME 44 3/4" RT (PXLS-7950, 7900)	0	UP7604	1
5	BOTTOM SIDE FRAME 53" LT (PXLS-7910)	0	UP7605	1
6	BOTTOM SIDE FRAME 53" RT (PXLS-7910)	0	UP7606	1
9	CROSS BRACE, SLANTED PLATE (PXLS-7950, 7900, 7910)	0	UP7611	4
10	OLYMPIC ADAPTER 1 X 8 (1 3/4 AXLE)	0	UP2595	12
12	RELEASE SAFETY SPOTTER HANDLE LT (PXLS-7950, 7910, 7900)	0	UP7626	2
13	RELEASE SAFETY SPOTTER HANDLE RT (PXLS-7950, 7910, 7900)	0	UP7627	2
14	SAFETY BAR SPOTTER LT (PXLS-7950, 7910, 7900)	0	UP7612	2
15	SAFETY BAR SPOTTER RT (PXLS-7950, 7910, 7900)	0	UP7613	2
16	SWING LOCK J-HOOK	0	UP7628	4
18	TOP CHIN-UP BRACE 43" W/KNURLING (PXLS-7950, 7900)	0	UP7615	1
20	TOP CROSS BRACE 43" W/HANDLES (PXLS-7910, 7920)	0	UP7629	1
23	UPRIGHT, SLANTED 5 DEG (PXLS-7950, 7910, 7900)	0	UP7620	4
24	UPRIGHT, WEIGHT HOLDER (PXLS-7950, 7930, 7910)	0	UP7621	2
25	ALUMINUM INSERT CAP 2 X 3		BNH1504	6
26	ALUMINUM INSERT CAP 3 SQ X .188		BNH1506	4
28	PHILLIPS SELF-DRILLING TEK SCREWS Z/P #10 X 3/4		BNH4265	24
30	HEX HEAD CAP SCREW GR-5 Z/P 1/2-13 X 1 1/4		BNH2167	24
32	HEX HEAD CAP SCREW GR-5 Z/P 1/2-13 X 3 1/2		BNH2801	8
33	HEX HEAD CAP SCREW GR-5 Z/P 1/2-13 X 4 1/2		BNH2802	20
34	HEX HEAD CAP SCREW GR-5 Z/P 1/2-13 X 4 3/4		BNH2168	4
35	HEX HEAD CAP SCREW GR-5 Z/P 1/4-20 X 3/8		BNH2803	10
37	FLAT WASHER Z/P 1/2 X 1 3/4 X 3/16		BNH2806	20
38	FLAT WASHER SAE Z/P 1/2"		BNH2031	52
39	NYLON INSERT THIN PATTERN LOCK NUT Z/P 1/2-13		BNH2027	10
40	PLASTIC TUBE GUIDE W/LIP-TEETH 3 1/2 X 3 1/2		BNH2874	16
42	NYLON INSERT LOCK NUT Z/P 1/2-13		BNH2029	20
43	RUBBER U-CHANNEL 19.75"LONG A85 BLK EPDM E-2179		BNH2795	4
45	RUBBER WASHER 1 7/8 ID X 4 1/4 OD X 9/16 TK		BNH0933	12
47	SPLIT LOCK WASHER Z/P 1/2"		BNH0572	28

# PXLS-7920 Parts List



ITEM	DESCRIPTION	PART NO.	QTY
51	YELLOW GRIP 3/4 X 5 1/16	BNH1515	4
52	Aluminum Insert Cap 1 1/4 RD with O-Rings	BNH2693	8
53	LABEL PROUDLY MADE IN THE USA 2 X 2 3/4	BNH1589	2
54	LABEL PROXL SAFETY SPOTTER ADJUSTMENT LEFT	BNH3011	2
55	LABEL PROXL SAFETY SPOTTER ADJUSTMENT RIGHT	BNH3012	2
56	LABEL PROXL UPRIGHT NUMBERS 1-22	BNH3010	4
57	LABEL SCHEDULE REPLACEMENT PARTS PROXL	BNH3013	1
59	LABEL WARNING BAR CATCH LEFT HAND	BNH2958	2
60	LABEL WARNING BAR CATCH RIGHT HAND	BNH2959	2
61	LABEL WARNING_SERIOUS INJURY OR DEATH	BNH2939	1
62	LABEL-DANGER MUST USE SPOTTERS...	BNH2905	2
63	LABEL DANGER SAFETY SPOTTER PROXL	BNH3018	4
64	LABEL-DANGER USE THIS EQUIPMENT...	BNH2903	2
65	LABEL-IMPORTANT FOR SMOOTH PERFORMANCE...	BNH2916	4
66	LABEL-INSPECTIONS RECOMMENDED INSPECTION...	BNH2915	1
67	LABEL-WARRANTY COMMERCIAL	BNH2927	1
68	FACILITY SIGN BE ALERT! THE FITNESS EQUIPMENT...	BNH3002	1
69	TUFFSTUFF LOGO ALUMINUM SMALL	BNH2463	3
70	TUFFSTUFF SER# ALUMINUM PLATE .5" X 1.8" X .02"	BNH1988	1
71	LABEL WARNING ANCHOR BOLT PROXL	BNH3016	6
72	LABEL WARNING ATTENTION USERS PROXL	BNH3019	2
73	LABEL WARNING MAXIMUM WEIGHT LOAD PROXL	BNH3020	2
74	OLYMPIC BAR STORAGE HOOK (PXLS)	UP7630	2
75	HEX HEAD CAP SCREW GR-5 Z/P 1/2-13 X 2 3/4	BNH2065	2



# COMMERCIAL WARRANTY

This warranty applies only in the United States to the products manufactured or distributed by TuffStuff Fitness Equipment Inc. under the TUFFSTUFF brand name. TuffStuff warrants to the original purchaser that TuffStuff equipment will be free from defects in material and workmanship. All warranty periods begin to run from the date of purchase to the original purchaser. The warranty and remedies set forth herein are conditioned upon proper storage, installation, use and maintenance and conformance with any recommendations of TuffStuff. This warranty does not cover products not manufactured by TuffStuff or products which are altered without the express written consent of TuffStuff.

### Commercial Warranty:

- Ten (10) Years:** Structural Main Frames, Welds, Cams and Weight Plates.
- Five (5) Years:** Pivot Bearings, Pulleys, Bushings, Guide Rods and Gas Shocks.
- One (1) Year:** Belts, Linear Bearings and Pull-Pin Components  
All other parts not mentioned elsewhere in the warranty will expire from the date of purchase to the original purchaser.
- Six (6) Months:** Upholstery, Cables, Finish and Rubber Grips.

The obligation of TuffStuff under this warranty is limited to repairing or replacing warranted defective parts as TuffStuff may elect, at TuffStuff's facility in Chino, California without charge to the purchaser. Purchaser is responsible for installation of repaired or replaced parts, and all transportation and insurance costs on returned or replaced equipment to and from TuffStuff's facility in Chino.

**THE FOREGOING SHALL CONSTITUTE THE SOLE REMEDY OF THE PURCHASER AND THE SOLE LIABILITY OF TUFFSTUFF WITH REGARD TO WARRANTY. NO IMPLIED STATUTORY WARRANTY OR IMPLIED STATUTORY WARRANTY OF MERCHANTABILITY OR FITNESS FOR A PARTICULAR PURPOSE SHALL APPLY. IN NO EVENT, WHETHER AS A RESULT OF BREACH OF CONTRACT, WARRANTY, NEGLIGENCE OR OTHERWISE, SHALL TUFFSTUFF BE LIABLE FOR SPECIAL, INCIDENTAL OR CONSEQUENTIAL DAMAGES INCLUDING, BUT NOT LIMITED TO, LOSS OF PROFITS OR REVENUE, LOSS OF USE OF EQUIPMENT, COST OF CAPITAL, COST OF SUBSTITUTION EQUIPMENT, DOWNTIME COST, OR CLAIMS OF CUSTOMERS OR PURCHASER FROM SUCH DAMAGE.**

This written warranty is the final, complete and exclusive agreement of the parties with respect to the quality or performance of the equipment and no action for breach of this written warranty or any implied warranty shall be commenced more than one (1) year after the accrual of the cause of action. No modification of this warranty or waiver of its terms shall be binding on either party unless approved in writing by an authorized representative of the party. Contact TuffStuff Fitness Equipment Inc. at 13971 Norton Avenue, Chino, CA 91710, before returning any defective equipment.

This warranty gives you specific legal rights and you may also have other rights, which may vary from state to state.

**SERIAL #**

Write your Serial number here for future reference

Purchase Date



**TuffStuff Fitness Equipment Inc.**

13971 Norton Avenue, Chino, CA 91710, USA Phone: 909-629-1600 Fax: 909-629-4967  
www.tuffstufffitness.com service@tuffstuff.net or service1@tuffstuff.net