

# PLATE LOADED



NOTE: Olympic weight plates and bar not included.

## ABDOMINAL CRUNCH



PPL-970

- Three-point rotation creates ideal arcing motion for the torso while simultaneously lifting the lower body upward.
- Unique design allows user to begin without any adjustment to the seat or movement arms.
- 5-position swivel seat isolates obliques for full core development.
- 9-1/2" weight horn.

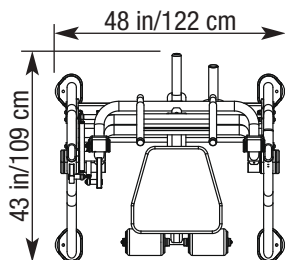

Ht: 70 in/178 cm Wt: 260 lb/118 kg

## SMITH MACHINE



PPL-900

- Self-aligning linear bearing Smith press system counter-balanced to 10 lbs. starting weight.
- 1500 lbs. load capacity Olympic Smith bar with 47" inside grip width.
- Fully adjustable spring action safety catches.
- Built-in Olympic weight storage.

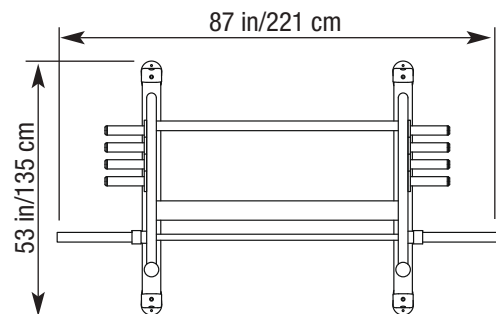

Ht: 91 in/231 cm Wt: 425 lb/193 kg