

FREE WEIGHT BENCHES & RACKS



Olympic weight plates, bar & spring collars not included.

POWER CAGE/RACK PPF-800

- Free standing double-sided racking system built for safety and variety.
- Dual pull-pin adjustments on the cross-beams bar support.
- Large walk-in area for easy access and maneuverability or bench workouts.
- Durable-welded knurled zinc plated multi-grip pull-up station for wide, narrow, reverse and neutral grip upper body exercises.
- Heavy gauge stainless steel bar hooks on the front and back uprights allow user to face in either direction to perform the exercises.
- Built-in band pegs top & bottom for various band resisted exercises.
- Built-in Olympic bar holder and Olympic weight storage.
- Maximum weight: 1000 lbs.

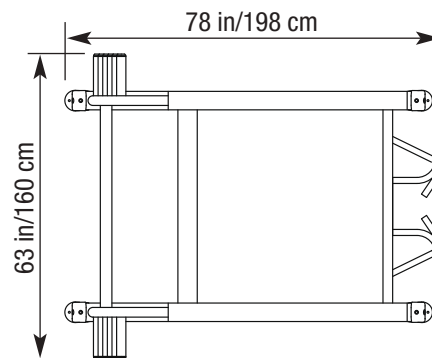

Ht: 95 in/241 cm
Wt: 505 lb/229 kg