

HTX-2000

DUAL-STACK FUNCTIONAL TRAINER

HTX-2000 is the ideal choice for those facilities searching for a compact, easy-to-use strength training platform for their clients and guests. Basic SPT-6 frame structure with the addition of a seated leg extension/standing leg curl station not commonly found with other functional trainers.
(2) 200 lbs. steel weight stacks.

LIGHT COMMERCIAL WARRANTY

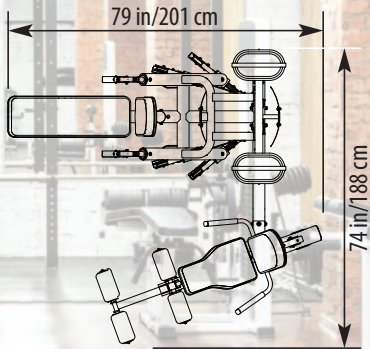

HT: 81 in/206 cm WT: 840 lb/381 kg

IDEAL FOR:

- Hotels & Motels
- Corporate Wellness
- Fire & Police Departments
- Community Centers
- Private Studios
- Apartments & Condominiums
- Medical & Rehab Centers
- Personal Training Facilities.

Multiple user participation on two separate exercise stations in one machine.



Chest Press

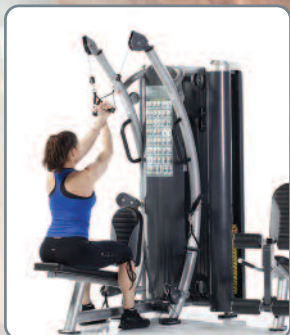

Lat Pulldown



Pectoral Crossover

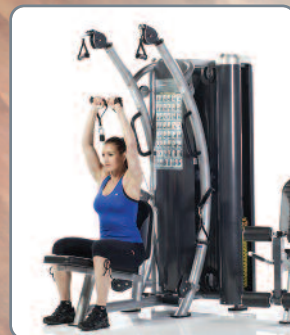

Shoulder Press



Seated Leg Extension