

# JUNGLE GYM SYSTEMS



## JUNGLE GYM 5-STATION



### PPMS-5000

- Crossover with built-in durable-welded knurled zinc plated multi-grip pull-up station for variety of upper body exercises.
- Customizable modular system offers the flexibility to choose your exercise stations and positioning that best suits your facility.
- Standard with full length protective steel weight shrouds.
- Swivel handles provide multi-directional, free and natural movements.
- Four (4) 200 lbs. steel weight stacks.  
(Option: 300 lbs. steel weight stack)

#### System as shown:

(1) Lat Pulldown; (1) Low Row; (2) Adjustable Hi/Low and (1) Pull-up station

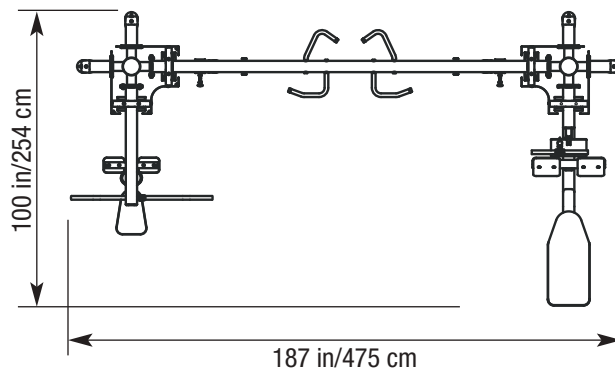

Ht: 90 in/229 cm Wt: 1720 lb/780 kg